

ASSEMBLY AND INSTALLATION INSTRUCTIONS

T0313

WARNING: TO AVOID RISK OF ELECTRICAL SHOCK, BE SURE TO SHUT OFF POWER BEFORE INSTALLING OR SERVICING THIS FIXTURE.

NOTE: 1. Before installing, consult local electrical codes for wiring and grounding requirements.
2. READ AND SAVE THESE INSTRUCTIONS.

Warning: LED electronics can be damaged by electro static discharge (ESD) shock. Before installation, discharge yourself by touching a grounded bare metal surface to remove this hazard. To avoid damage, do not touch the LED module.

Hardware Package (included):

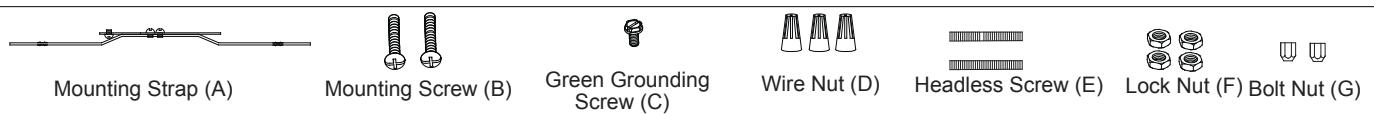

Installation steps

Turn off the power at fuse or circuit box.

1. Thread two headless screws to the mounting strap, and then secure with two lock nuts. Adjust the length of the fixture mounting screws if necessary.
2. Attach the mounting strap to the outlet box by using two mounting screws.
3. Pull out the source wires from the outlet box. Make wire connections using wire nuts as follows:
 - Connect the black wire from the fixture to the black wire from the power source.
 - Connect the white wire from the fixture to the white wire from the power source.
 - Attach the fixture grounding wire to the mounting strap with the green grounding screw, and then connect it to the house grounding wire with a wire nut.

Carefully put the wires back into the outlet box.

4. Attach the ceiling pan to the mounting strap by inserting the headless screws, then secure it with two bolt nuts.

Turn on the power at fuse or circuit box.

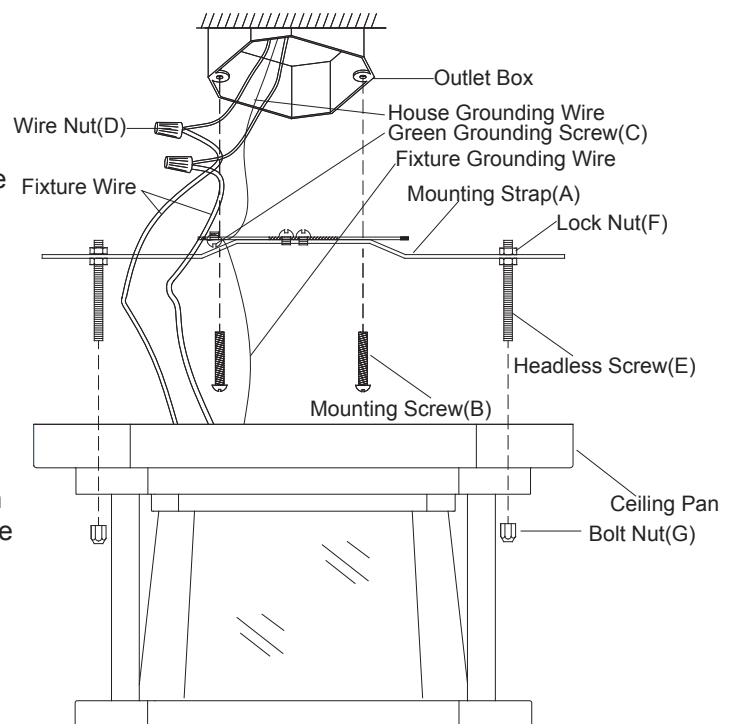

The following parts are available for re-order if damaged or missing.

Spare Parts List:

Mounting Strap (A)	Mounting Screw (B)	Green Grounding Screw (C)	Wire Nut (D)	Headless Screw (E)	Mounting Hardware 5628MM(1 SET)
Lock Nut (F)	Bolt Nut (G)				

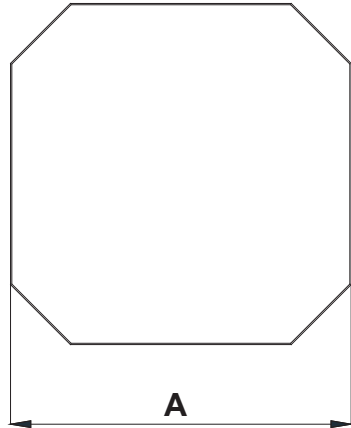
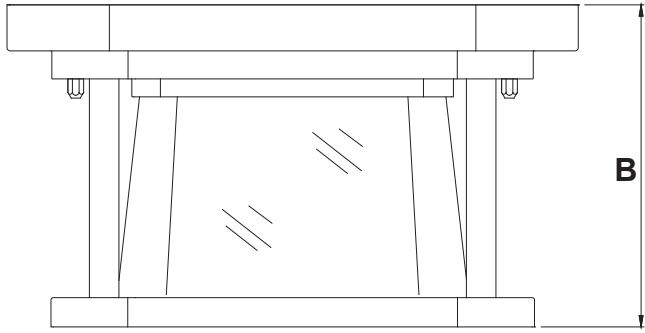

A: 10"
B: 6"