

ASSEMBLY AND INSTALLATION INSTRUCTIONS

T0502

WARNING: TO AVOID RISK OF ELECTRICAL SHOCK, BE SURE TO SHUT OFF POWER BEFORE INSTALLING OR SERVICING THIS FIXTURE.

NOTES: 1. Before installing, consult local electrical codes for wiring and grounding requirements.
2. READ AND SAVE THESE INSTRUCTIONS.

Hardware Package (included):

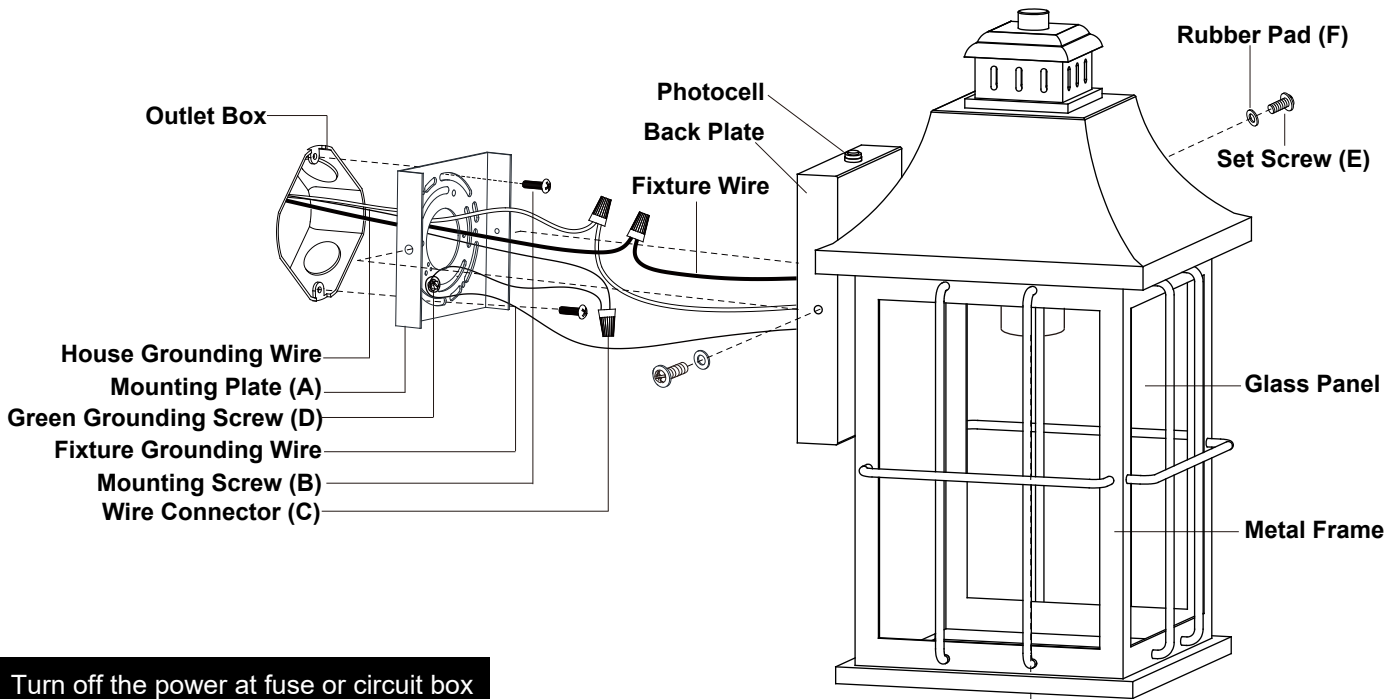
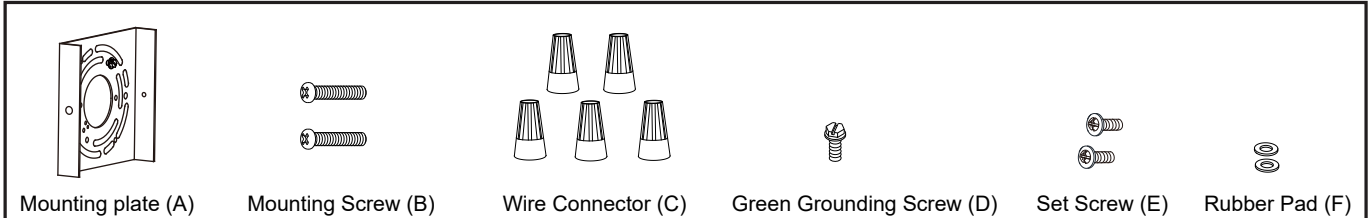

Turn off the power at fuse or circuit box

1. Remove the set screws (E) to separate the mounting plate (A) from the fixture.
2. Attach mounting plate (A) to the outlet box using two mounting screws (B).
3. Make the bottom of the fixture upward, gently place three glass panels into the metal frame, then press the clips to secure the glass panels.(Fig.1)



Bulb Type A Max.60W
(not include)

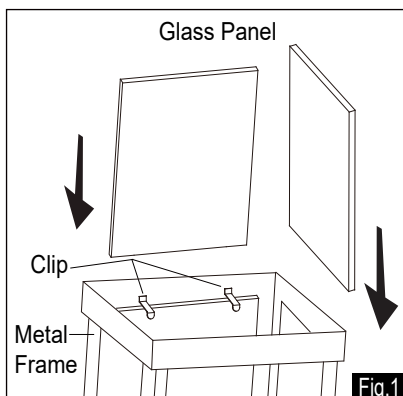

 VAXCEL

181211

4. Pull out the outlet wires and the house grounding wire from the outlet box. Make wire connections using the wire connectors (C):
 - Connect the black wire from the fixture to the black wire from the power source.
 - Connect the white wire from the fixture to the white wire from the power source.
 - Attach the fixture grounding wire to the mounting plate (A) with the green grounding screw (D). connect it to the house grounding wire with a wire connector (C).
 Then carefully put the wires back into the outlet box.

5. Attach the fixture to the mounting plate (A), and then secure it with two rubber pads (F) and set screws (E).

CAUTION: With silicone caulking compound, caulk completely around where the back plate meets with the wall surface to prevent water from seeping into the outlet box.

6. Install a bulb (not included). See relamping label at socket area or packaging for maximum allowed wattage.

Turn on the power at fuse or circuit box

Operation the Unit Without Photocell

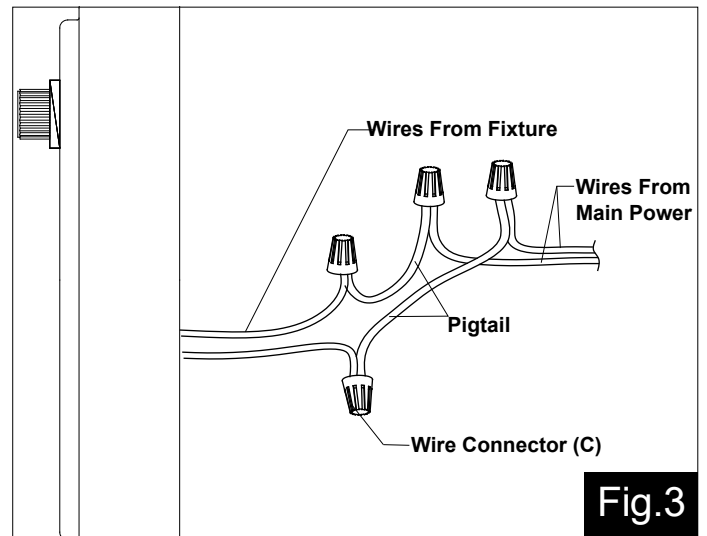
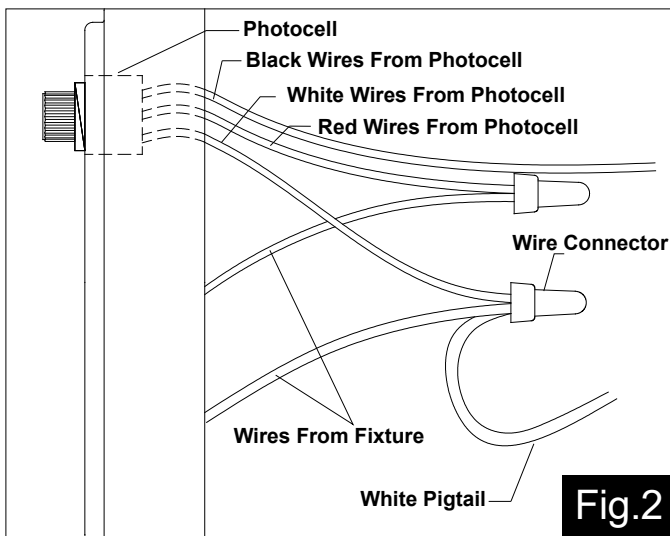

1. Turn off the power at the main fuse or circuit breaker box before starting installation.
2. Loosen the wire connectors connected with the wires from photocell. (See Fig.2)

Note: Do not move the photocell to prevent water from seeping into the outlet box.
3. Take a white pigtail and black pigtail and make wire connections using wire connectors (C): (See Fig.3)
 - a. The black wire from the fixture to one end of the black pigtail.
 - b. The white wire from the fixture to one end of the white pigtail.
 - c. The other end of the black pigtail to the black wire from the power source.
 - d. The other end of the white pigtail to the white wire from the power source.
 Put all wires back into the back plate of the fixture.

Turn on the power at fuse or circuit box

The following parts are available for re-order if damaged or missing.

Spare Parts List:

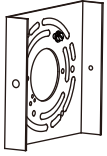

Mounting plate (A)



Mounting Screw (B)

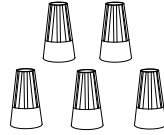

Wire Connector (C)

→ Assembly Kit
6053MM (1SET)



Green Grounding Screw (D)



Set Screw (E)



Rubber Pad (F)



Glass Panel
10071RG (1SET)

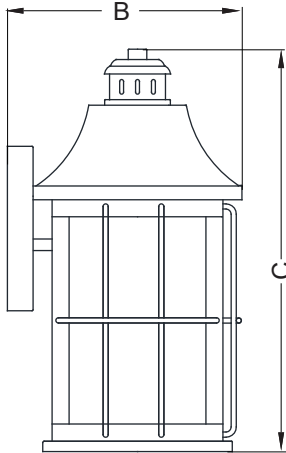
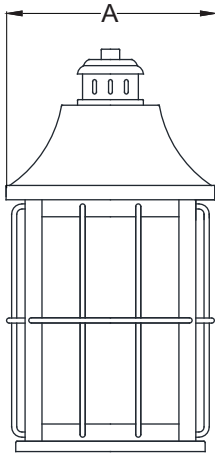

A: 8"

B: 9"

C: 15-3/4"